

# Flexible Vertical Conductive Connectors

1.0



ENCOMPASS LIGHTING GROUP  
2-CIRCUIT MONORAIL

## GENERAL PRODUCT INFORMATION:

This product is suitable for dry locations only.

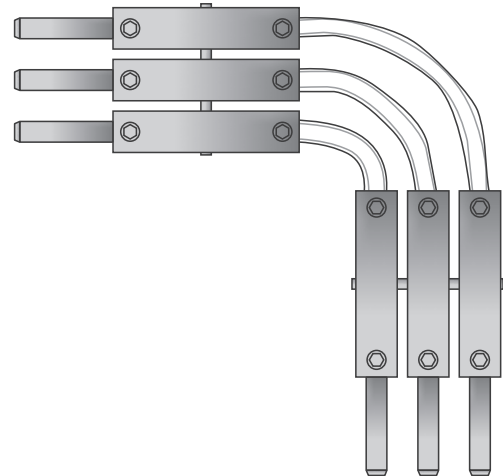

## Adjust the Angle

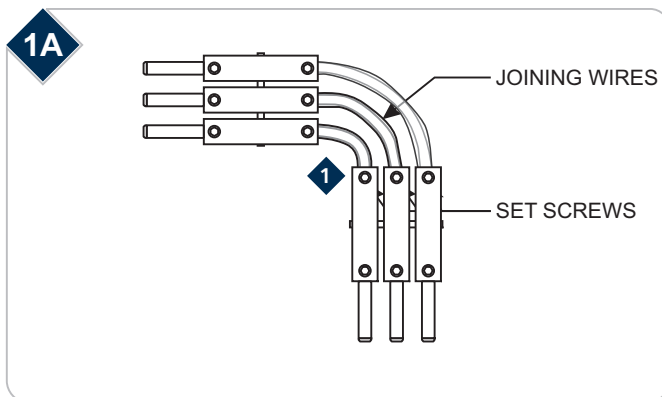

The joining wires on the flexible connectors are pre-cut for a 90-degree bend. For any angle other than 90 degrees, follow these instructions to adjust the wires. Otherwise, skip ahead to section 2.

- 1 Loosen the inner set screws on one connector with an Allen wrench.
- 2 Pull the wires out of the connector.

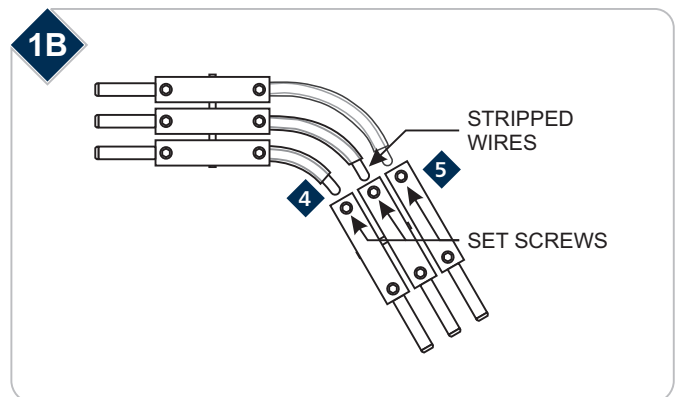

- 3 Trim the wires to the proper length and strip off the last 3/8" of the insulation.
- 4 Insert the stripped wires into the connector.
- 5 Tighten the set screws with an Allen wrench to secure the wires.

## Connect the Monorail Sections

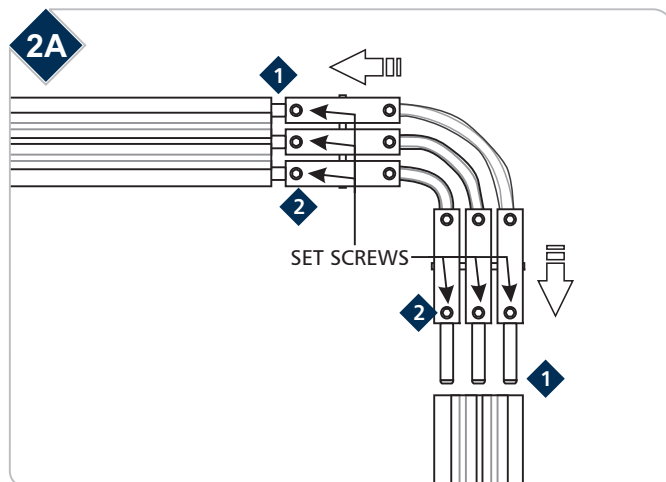

- 1 Push the connectors completely into the MonoRail.
- 2 Tighten all six outer set screws with an Allen wrench. To avoid heat build up and corrosion, make sure all set screw connections are tight.

**SAVE THESE INSTRUCTIONS!**



**ENCOMPASS LIGHTING GROUP**

7400 Linder Ave, Skokie, IL 60077  
847.410.4400

[www.encompasslighting.com](http://www.encompasslighting.com)

© 2008 Encompass Lighting Group. All rights reserved. The "Encompass Lighting Group" graphic is a registered trademark of Encompass Lighting Group. Encompass Lighting Group reserves the right to change specifications for product improvements without notification.

A Generation Brands Company